

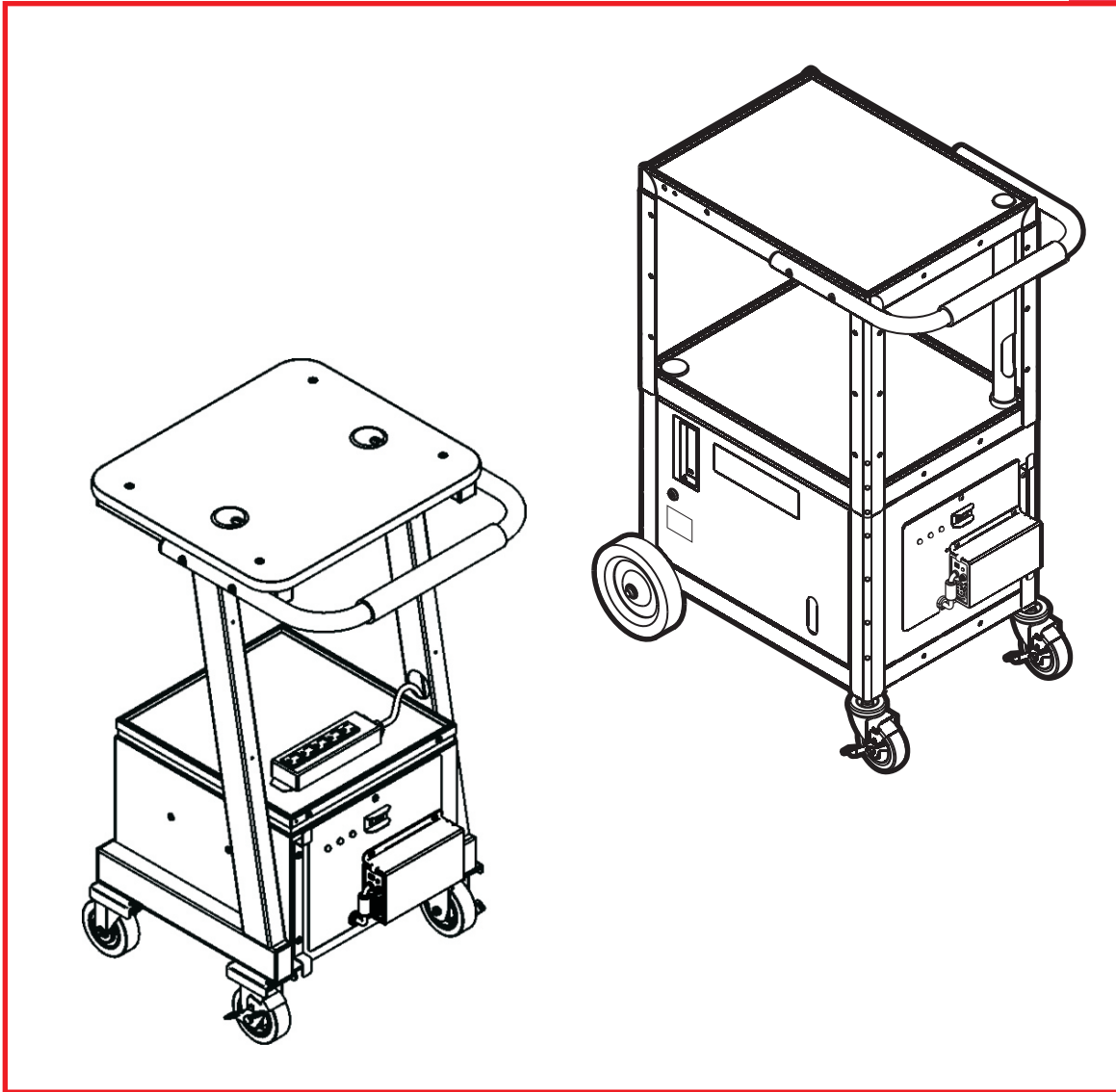

Operating Instructions

Monarch® 9876™ and 9878™
Mobile Work Station (MWS™)



Each product and program carries a respective written warranty, the only warranty on which the customer can rely. Avery Dennison Corp. reserves the right to make changes in the product, the programs, and their availability at any time and without notice. Although Avery Dennison Corp. has made every effort to provide complete and accurate information in this manual, Avery Dennison Corp. shall not be liable for any omissions or inaccuracies. Any update will be incorporated in a later edition of this manual.

©2007 Avery Dennison Corp. All rights reserved. No part of this publication may be reproduced, transmitted, stored in a retrieval system, or translated into any language in any form by any means, without the prior written permission of Avery Dennison Corp.

WARNING

This equipment has been tested and found to comply with the limits for a Class A digital device, pursuant to Part 15 of the FCC Rules. These limits are designed to provide reasonable protection against harmful interference when the equipment is operated in a commercial environment. This equipment generates, uses, and can radiate radio frequency energy and, if not installed and used in accordance with the instruction manual, may cause harmful interference to radio communications. Operation of this equipment in a residential area is likely to cause harmful interference in which case the user will be required to correct the interference at his own expense.

CANADIAN D.O.C. WARNING

This digital apparatus does not exceed the Class A limits for radio noise emissions from digital apparatus set out in the Radio Interference Regulations of the Canadian Department of Communications.

Le présent appareil numérique n'émet pas de bruits radioélectriques dépassant les limites applicables aux appareils numériques de la classe A prescrites dans le Règlement sur le brouillage radioélectrique édicté par le ministère des Communications du Canada.

Trademarks

Monarch®, 9876 and 9878 are registered trademarks of Avery Dennison Corporation.

Avery Dennison
170 Monarch Lane
Miamisburg, OH 45342



TABLE OF CONTENTS

GETTING STARTED	1-1
About the MWS	1-1
About the 9876 Optional Accessories	1-1
Attaching the Hanging Folders	1-2
Connecting the Power Cord	1-2
Routing the Cables (9878 MWS)	1-2
Safety Precautions	1-3
Audience	1-3
Calling Service	1-3
CHARGING THE BATTERIES	2-1
Important Battery Safety Information	2-1
Battery Life	2-2
About the Battery Charger	2-2
Important Charging Information	2-3
Key Switch	2-3
Charger LEDs	2-4
Frequency of Charging/Run-Time Guidelines	2-4
SPECIFICATIONS	A-1
MWS	A-1
Batteries	A-1
Chargers	A-2
Two Batteries	A-2
Inverters	A-2
WIRING DIAGRAMS	B-1
24v with DC-to-DC Converter, 12v (9876)	B-2
24v with 700w Inverter (9876/9878)	B-3
24v with 1,000 Watt Inverter (9876/9878)	B-4

GETTING STARTED

1

Use the Monarch® 9876™ and 9878™ Mobile Work Station™ (MWS™) for mobile printing.

About the MWS

The MWS ships mostly assembled. There are optional accessories available for the 9876 MWS that may require some assembly.

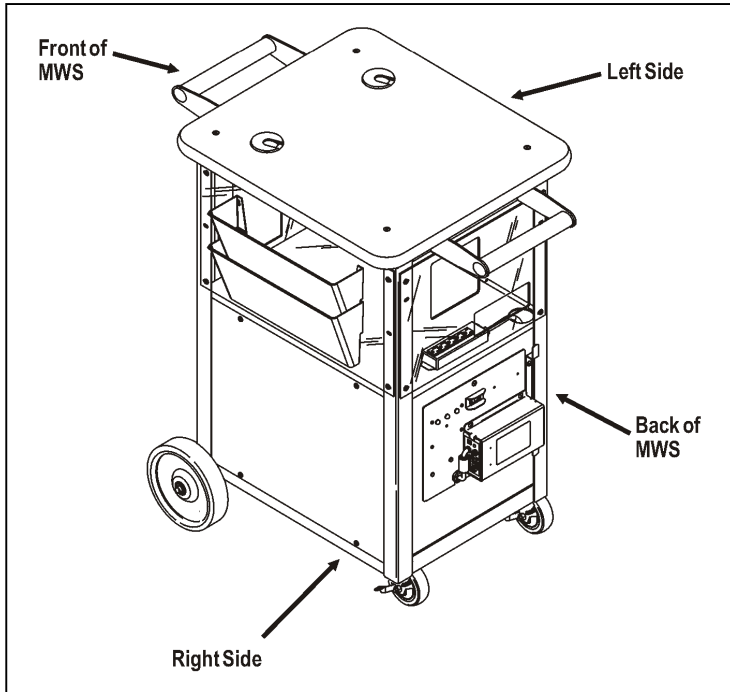

9876 MWS

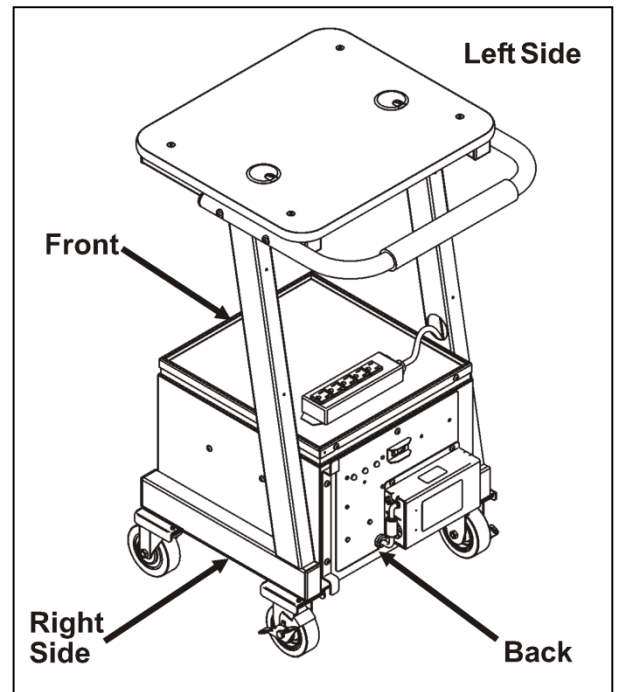

9878 MWS

About the 9876 Optional Accessories

To assemble the options, you may need a 5/32" Hex wrench, and a Phillips screw driver.

The 9876 MWS has combinations of doors and solid panels. The door enclosures should already be attached to the MWS.

Note: Use water or a glass and surface cleaner to clean the door enclosures. **Do not use solvents on these enclosures.** A solvent will damage the door enclosure.

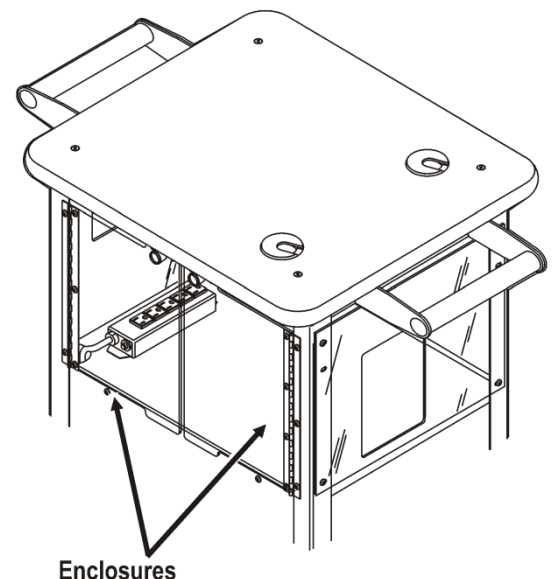

Attaching the Hanging Folders

Follow the steps below to attach the hanging folders to the 9876 MWS.

1. Remove the following items from their packaging:

- (1) file folders
- (4) 3/8" plastite screws (may already be attached to panel)

2. Use the assembly instructions provided with the file folders to assemble folders to the MWS panel.
3. Tighten the screws.

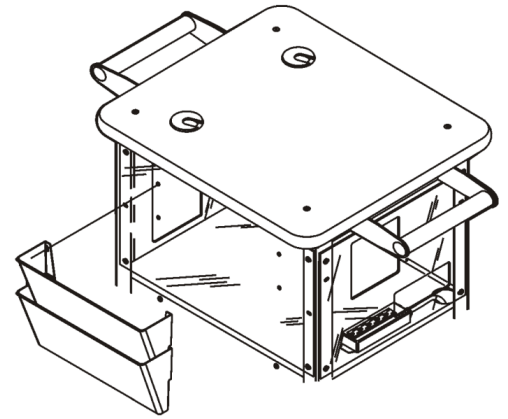

Connecting the Power Cord

Connect the charger's power cord to the power inlet. Power cords are not included with International models.

Note: The charger's power switch does not control the MWS power. The MWS power switch located on the power panel controls power to the MWS and connected devices.

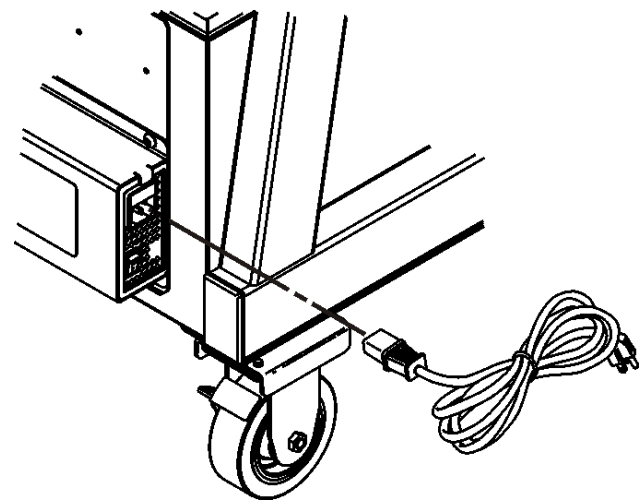
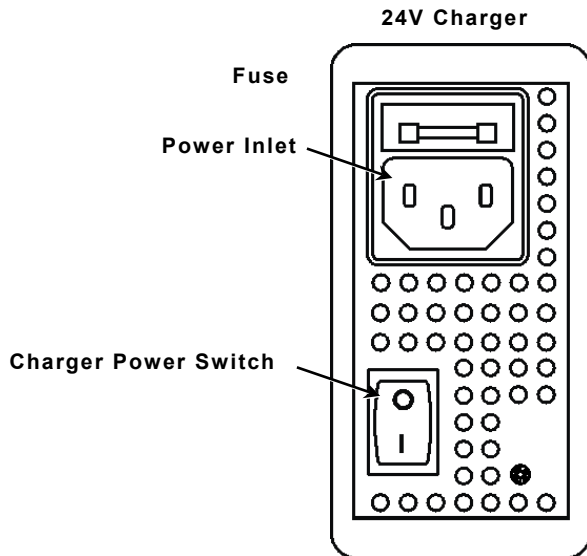

Routing the Cables (9878 MWS)

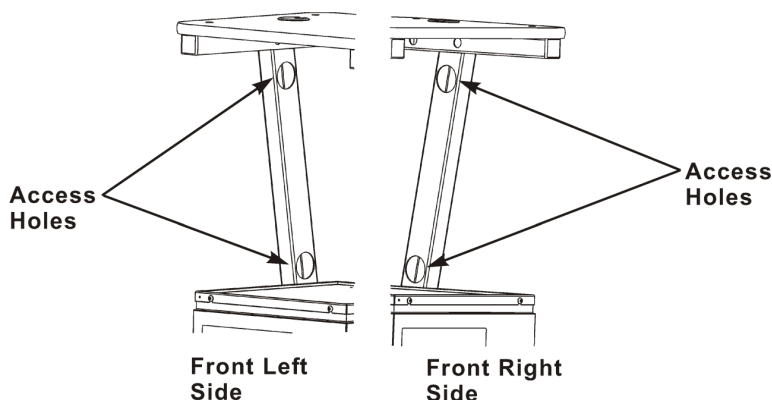

Use the four access holes to route the cables on the MWS.

Safety Precautions

- ◆ Batteries are installed by Avery Dennison personnel and are specified to be a type suitable for the country of use.
- ◆ Power strip is installed by Avery Dennison personnel and is specified to be a type suitable for the country of use.
- ◆ Fuses are provided by Avery Dennison and replaced by Avery Dennison personnel only.

The following symbols are used in this manual to show the importance of safety when using the MWS.

WARNING	Failure to follow the guidelines marked with this symbol could result in serious personal injury or death.
CAUTION	Failure to follow the guidelines marked with this symbol could result in minor personal injury or product damage.
	Caution, risk of electrical shock. Also known as the "High Voltage" symbol.

Audience

This manual is designed for the person using the MWS for mobile printing applications.

After you receive the MWS, you should have all the necessary parts, including the batteries and charger. Keep the boxes and packaging material in case the MWS ever needs repair.

Calling Service

If these solutions do not work or you have a problem not listed, see your System Administrator or call Service at the number listed on the back of this manual.

CHARGING THE BATTERIES

2

The battery charger is a fully automatic, maintenance-free charger. Dispose of used batteries according to the manufacturer's instructions.

CAUTION: The charger's power switch does not control MWS power. The MWS power switch, located on the power panel, controls power to the MWS and connected devices.

To charge the battery, plug the MWS's AC power cord into a grounded outlet.

Charge the battery:

- ◆ before using the MWS for the first time (charge it for 7 hours)
- ◆ when the MWS beeps (see "Battery Life" for indications of low battery conditions)
- ◆ when the MWS is not in use.

You may be able to operate equipment connected to the MWS for up to four hours while the cart is charging. However, use of MWS equipment results in slower charge rates.

For optimal performance, we recommend that you turn off all equipment and allow the MWS to achieve a full charge before returning the MWS to use.

You cannot overcharge the battery. The battery charger is "intelligent"; it monitors the battery condition and does not overcharge the lead acid battery. Battery life is extended by frequent charging.

CAUTION: Only qualified service personnel may install or replace the two 12-volt (55 or 75 amp-hours) sealed lead-acid non-venting batteries on the MWS.

If replacing batteries, you must use the same type of battery from the same manufacturer (as the ones provided with the MWS). Make sure the batteries are NRTL-recognized. Also, BOTH batteries MUST be replaced at the same time to maintain capacity match.

Important Battery Safety Information

- ◆ Never smoke or allow a spark or flame in vicinity of battery.
- ◆ **Do not** drop a metal tool on the battery. The resulting spark or short-circuit on the battery or other electrical part may cause an explosion.
- ◆ Remove personal metal items such as rings, bracelets, necklaces, and watches when working with a lead-acid battery. A lead-acid battery produces a short-circuit current high enough to weld a ring to metal, causing a severe burn.

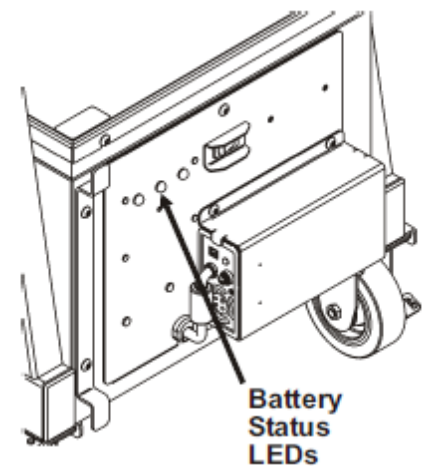

Battery Life

The MWS Battery Status LEDs are located on the top-left side of the Power Panel. To use the Battery Status LEDs, the MWS must be on.

If you leave the battery charger plugged in and constantly charging **when the MWS is not in use (turn MWS power off)**, the battery life is maximized for the application. The charger does not overcharge the batteries.

The MWS has signal lights to indicate the battery status as follows. The following voltages are an approximation and should be used for reference only.

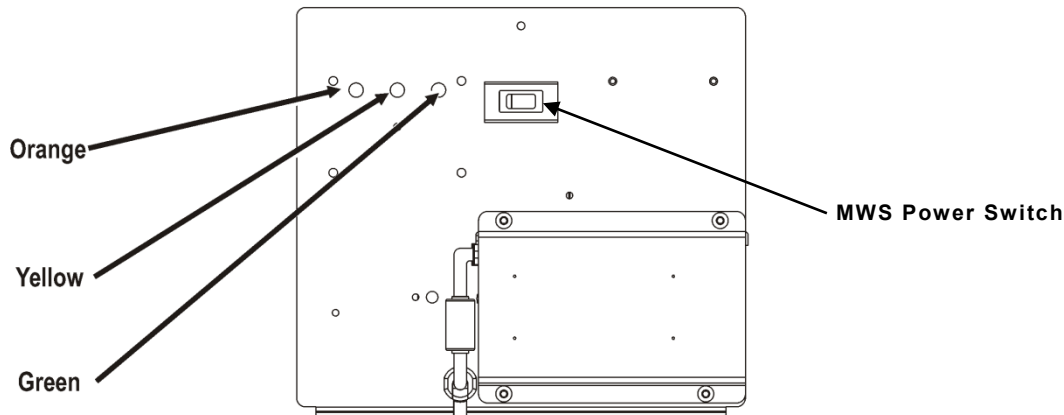

Flashing Orange Warning! The batteries need immediate charging. The MWS beeps continuously to alert you of this condition. (Early models have red lights instead of orange).

Flashing Yellow Caution! Finish printing the batch, then recharge the MWS. The batteries are getting low.

Flashing Green Go! The batteries are charged to approximately 75% or better capacity.

If the CHARGE light does not turn on, make sure the charger is properly connected to the batteries and the charger has AC power.

If the READY light does not turn on after 18 hours, the batteries are deeply discharged. Call Technical Support or replace the batteries.

About the Battery Charger

- ◆ Store the charger in a dry area not subject to prolonged below freezing temperatures.
- ◆ The “intelligent” battery charger monitors the batteries condition and does not overcharge the batteries. It is recommended to leave the battery charger plugged in and charging when the MWS is not in use. Battery life is extended by frequent charging.
- ◆ The charger’s Green light is on when the battery is finished charging. Leaving the charger plugged in prevents the battery from self-discharging.
- ◆ The MWS Battery Status LEDs provide the most accurate indication of battery status. While the 24VDC charger has Percentage LEDs that also show battery status, use the three Battery Status LEDs on the Power Panel.

Important Charging Information

WARNING: DANGER! RISK OF ELECTRICAL AND FIRE HAZARD. CERTAIN ACTIONS MAY RESULT IN DEATH, SERIOUS INJURY, SHOCK, OR BURNS.

- ◆ **Do not** disassemble the battery charger.
- ◆ **Do not** operate the charger if it has been damaged in any way. Do not spill liquids into the charger, such as water or soft drink.
- ◆ **Do not** expose the battery charger to rain or snow. Never charge a frozen battery. The colder the battery, the longer it takes to charge.
- ◆ Plug only into a three-prong grounded outlet. **Do not** alter the AC power cord or plug provided. **Do not** operate the battery charger with a damaged cord or plug.
- ◆ **Do not** let the battery remain fully or partly discharged for a long time; keep it charged.
- ◆ If using an extension cord, you must use 18 gauge or heavier for lengths up to 50 feet, or 16 gauge or heavier for lengths up to 100 feet. Use of improper extension cord could cause fire and electric shock. Use an extension cord bearing the UL listing mark and rated for four Amperes or greater current capacity.
- ◆ Pull on the plug rather than the cord when disconnecting the battery charger. Locate the cords where they will not be stepped on, tripped over, or otherwise subjected to damage or stress.
- ◆ The batteries must be charged when the total voltage is less than 21V. The charger will not charge if the total voltage is less than 5V. If the total voltage is less than 5V, you need new batteries.

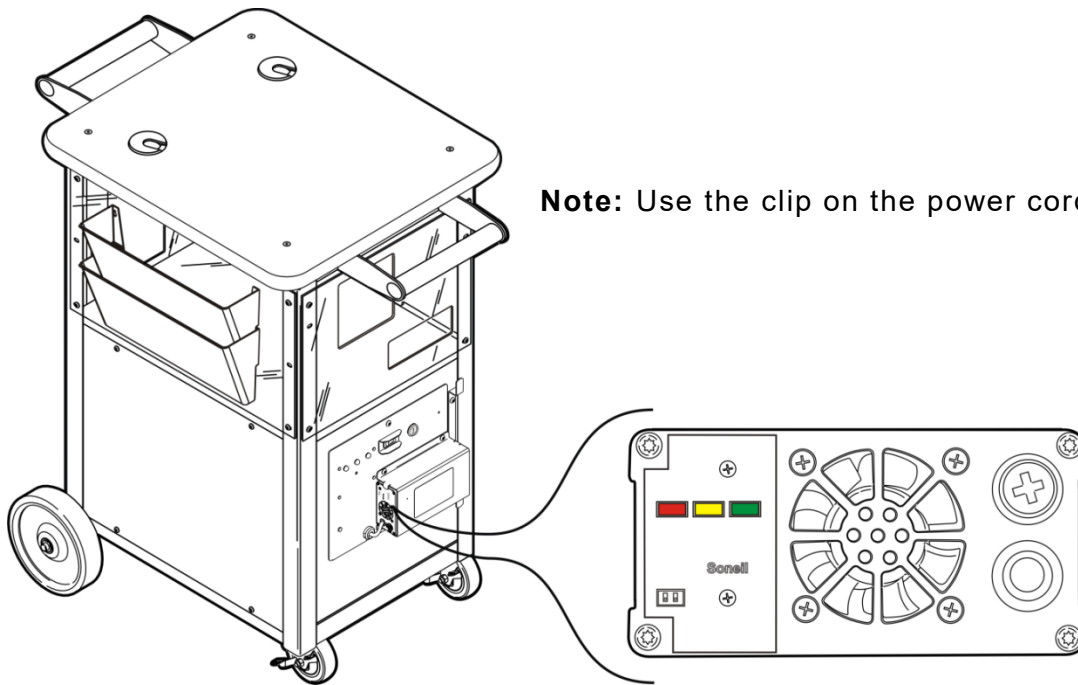

Note: Use the clip on the power cord to secure it in place.

Key Switch

The key switch requires the key to turn on/off the mobile work station's power. The key cannot be removed when the cart's power is ON. When storing the mobile work station, keep the key in a secure location. Losing the key will result in a Service call and replacement of the part; there is not a master key.

Charger LEDs

Use this table to read the charger's LEDs:

Description	Status		
	Red LED	Yellow LED	Green LED
Calibrating charger	BLINKING	OFF	BLINKING
Preparing to charge	OFF	ON	OFF
Charging	ON	OFF	OFF
Completing charge	ON	BLINKING	OFF
Batteries are charged (fan off)	OFF	OFF	ON
Error	BLINKING	ON	BLINKING

Note: Chargers using firmware version 3.0 and later indicate firmware version using LED blinks. For example, upon power up, a charger with firmware version 3.0 will indicate this with three Red LED blinks (the green LED will not blink). Subsequent releases, such as version 3.2 will indicate with three Red LED blinks and two Green LED blinks.

Frequency of Charging/Run-Time Guidelines

The following information is approximate and should be used for reference. Many factors affect an individual battery's performance:

- ◆ the presence of auxiliary devices
- ◆ the printing rate (including printhead contrast and number of labels per day)
- ◆ the complexity of your printed formats
- ◆ the environment (temperature and humidity in your facility or DC).

"Typical conditions" are defined as:

one Monarch printer printing standard compliance 4x6 labels (5-10 minutes of actual printing per hour), no auxiliary devices attached to the MWS, and standard environmental conditions (no excessive heat or humidity).

- ◆ When using the 24VDC or Symbol 24VDC MWS under typical conditions, the batteries may last up to 50 to 100 hours before recharging.
- ◆ When using the AC Power Inverter or 24VDC/115VAC MWS under typical conditions, the batteries may last up to 24 hours before recharging.
- ◆ When you notice the batteries need to be charged more frequently, order replacement batteries. **BOTH batteries MUST be replaced at the same time to maintain capacity match.** For example, if you had 60 hours of use between charges and now have 30 hours of use between charges, replace the batteries.

Note: The performance of your batteries varies depending on the number of printers and/or auxiliary devices, such as a scanner or terminal, attached to the MWS. Frequent charging of the batteries is recommended.

Turn off the MWS power switch (which turns OFF all connected equipment) whenever the MWS will be idle for an extended period of time.

SPECIFICATIONS

A

MWS

The specifications for the 9876 and 9878 mobile work stations are listed below.

	9876	9878
Height:	≈42 inches (1067 mm) depending on selected options	≈37 inches (940 mm) depending on selected options
Top Width:	23 inches (584 mm)	20.5 inches (521 mm)
Length:	28 inches (711 mm)	22 inches (559 mm)
Weight:	≈225 lbs (103 kg) depending on selected options	≈115 lbs (52 kg) depending on selected options
Power Cabinet Lower Shelf:	N/A	15 inches wide x 16 inches long (381 mm x 406 mm)
Top Shelf : (Laminated Top)	N/A	20 inches wide x 16 inches long (508 mm x 406 mm)
Operating Limits:	40°F to 95°F (5°C to 35°C) with thermal transfer supplies	40°F to 95°F (5°C to 35°C) with thermal transfer supplies
Storage:	15°F to 120°F (-9°C to 49°C)	40°F to 120°F (5°C to 49°C)
Humidity:	5% to 90% non-condensing	5% to 90% non-condensing

Batteries

- ◆ (2) 12-volt, 55 amp-hours or 75 amp-hours, AGM (non-flooded) deep cycle batteries. The batteries are labeled with the amp hour and voltage information.
- ◆ Sealed lead-acid, non-venting (safety venting only), no transportation restrictions.
- ◆ Shelf Life/Charge Retention:
 - 1 month 97%
 - 3 months 91%
 - 6 months 85%
- ◆ Cycle Use:
 - 100% depth of discharge approx. 250 cycles
 - 50% depth of discharge approx. 550 cycles
 - 30% depth of discharge approx. 1200 cycles

Cycle Life is approximate and many factors affect an individual battery's performance.

Chargers

Two Batteries

Input 180-264 VAC @ 3.0 - 1.5 A
50/60 Hz
IEC 320-C14 Connection

Output 24 VDC, 8 Amps DC charging current

- ◆ Reverse polarity and short circuit-proof
- ◆ 8 to 11 hours full charge, typical recharge time is 3 to 8 hours
The recharge time depends on the battery size and amount of charge remaining.
- ◆ 20 to 100 hour typical battery duration
The duration varies based on the equipment powered by the Mobile Work Station and the frequency of use for the equipment.
- ◆ Smart charging

Note: Use only NRTL-listed (National Recognized Testing Lab) accessories.

Inverters

Two inverters are available: 700 or 1,000 watt.

	700 watt	1,000 watt
Input Voltage:	21 to 33VDC	21 to 30VDC
No Load Current:	0.8A	0.75A
Frequency:	50/60 Hz \pm 0.3%	50/60 Hz \pm 0.3%
Output Voltage:	110VAC \pm 5%	110VAC \pm 3%
Output Power:	700W RMS (continuous)	1000W RMS (continuous)
Surge Power:	1000W RMS (1 second)	2000W RMS (1 second)
Output Waveform:	Pure Sine Wave (THD<3%)	Pure Sine Wave (THD<3%)
Typical Efficiency:	93%	92%
Operating Temperature	-4°F to 105°F (-20°C to 40°C)	32°F to 105°F (0°C to 40°C)

WIRING DIAGRAMS

B

This appendix contains wiring diagrams for the various power options:

- ◆ 24v with DC-to-DC Converter, 12v (9876)
- ◆ 24v with 700w Inverter (9876)
- ◆ 24v with 1,000 Inverter (9876/9878)

WARNING Only qualified service personnel may install or replace the two 12-volt sealed lead acid batteries used to power the printer on the Station.

If a battery needs to be replaced, BOTH batteries MUST be replaced at the same time to maintain capacity match. One or two power sparks may occur (this is normal) when installing or changing the fuses.



028028

Avery Dennison
170 Monarch Lane
Miamisburg, OH 45342

1-800-543-6650 (In the U.S.A.)
1-800-387-4740 (In Canada)
www.monarch.com

